

QTS[®] Industrial Series Model QTS-5

Parts Manual

Record of Change 101

This manual contains important safety information and must be carefully read in its entirety and understood prior to installation by all personnel who install, operate and/or maintain this product.

Parts ordering and product warranty information is available at www.quincycompressor.com

Manual No. 50316-101

February 2010 Edition

TABLE OF CONTENTS

Model & Serial Number Identification..... 1
Ordering Replacement Parts 1
Quin-Cip Lubricant 2
Crankcase Lubricant Capacity 2
Gasket Set 2
Recommended Spare Parts 2
Crankcase Group 3
Crankshaft Group 4
Connecting Rod & Piston Groups 5-6
Cylinder & Head Groups 7-8
Discharge Manifold Kit 9
Typical Unit Repair Parts List 10

INTRODUCTION

This manual provides information for the Model QTS-5 reciprocating compressor, per Record of Change 101.

The Model QTS-5 is an aircooled, single stage, four cylinder, splash lubricated compressor, with up to 125 PSIG continuous pressure capability. It has a 2.75" bore and a 2" stroke. This compressor can be run at 600-1030 RPM.

CHANGES

Since last printing dated August 2006:

The head and cylinder fasteners and head gasket were redesigned.

SERIAL NUMBER IDENTIFICATION

The unit serial number identification tag is located on the air tank top plate. The basic compressor serial number decal is located on the side of the crankcase opposite the oil fill side. *Fill in the numbers from your compressor unit and basic compressor in the corresponding spaces provided here, and reference this page when ordering replacement parts.*

Unit Serial Number

Basic Serial Number

All replacement parts are to be ordered through an authorized Quincy distributor. Insist on genuine Quincy parts only! Failure to do so may void warranty.

ORDERING REPLACEMENT PARTS

Prompt service can be rendered on repair parts orders if the following information is given:

- Item 1)** the model number, record of change number, & serial number.
- Item 2)** the exact part number needed. (Do not order by item numbers.)
- Item 3)** the exact quantity needed.
- Item 4)** the preferred type of transportation.

QUIN-CIP LUBRICANT

Refer to the chart below to order Quin-Cip-D or Quin-Cip compressor lubricant from your local authorized Quincy distributor.

Quin-Cip-D Lubricant (synthetic)	
SAE 30 (ISO 100)	
Quart	115468Q
Case (12 Qts.)	115468C
Quin-Cip Lubricant	
SAE 10W (ISO 32)	
Quart	112541Q032
Case (12 Qts.)	112541C032
SAE 20 (ISO 68)	
Quart	112542Q068
Case (12 Qts.)	112542C068
SAE 30 (ISO 100)	
Quart	112543Q100
Case (12 Qts.)	112543C100

Gasket Set 114097-003		
Qty.		Description
2	112591	cylinder gasket
1	114918	bearing carrier gasket
2	114201-001	head gasket
2	112793	cylinder to valve plate gasket
1	115058-001	crankshaft seal
1	22749-112	dipstick "o"ring

Recommended Spare Parts		
Qty.	Part Number	Description
2	112845-06	air filter element
2	113047-001	valve repair kit
1	114097-003	gasket set

CRANKCASE LUBRICANT CAPACITY

Model	Capacity
QTS-5	1 qt. & 8 oz. (1.18 lit.)

CAUTION !
Refer to the QT & QTS Series instruction manual for vital lubrication information.

CAUTION !
Follow all safety precautions outlined in the QT & QTS Series instruction manual.

WARNING !
Do not operate this compressor without a totally enclosed belt guard or any other required safety equipment.

DANGER !
Air used for breathing or food processing must meet OSHA 1910.134 or FDA 21 CFR 178.3570 regulations. Failure to do so may cause severe injury or death.

114940 CRANKCASE GROUP

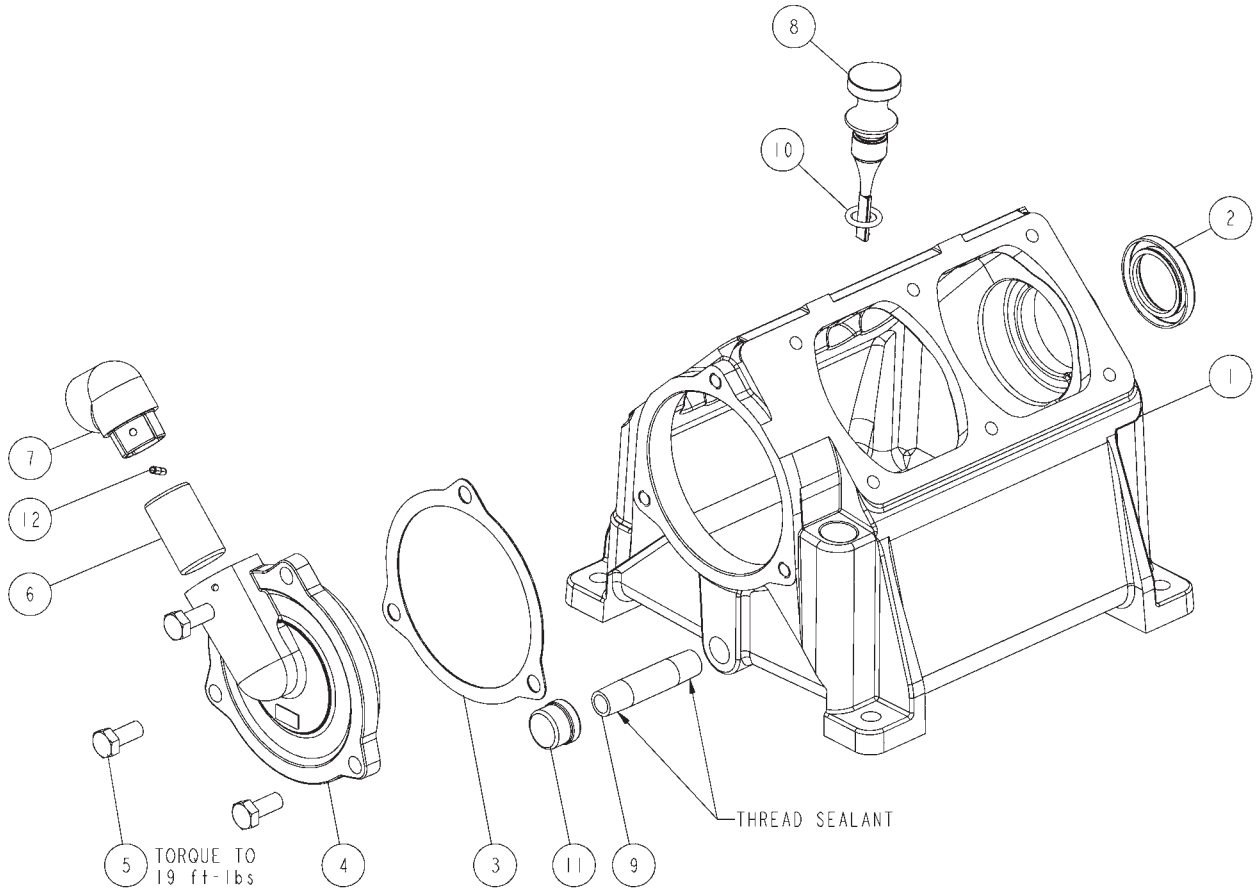

ITEM	PART NUMBER	QTY	DESCRIPTION
1	114871	1	CRANKCASE
2	115058-001	1	VITON OIL SEAL
3	114918	1	GASKET
4	114872	1	BEARING CARRIER
5	115037-K10	3	SCREW, CAP HEX, SEALANT, GRADE 5
6	111333-002	1	FILTER
7	111349-001	1	BREATHER ELBOW
8	110070-9	1	DIPSTICK
9	125933-013	1	PIPE NIPPLE, 1/4 NPT X 2.38
10	22749-112	1	O-RING, VITON
11	4693	1	PIPE CAP
12	115808-F14	1	SPRING PIN

114941-001 CRANKSHAFT GROUP

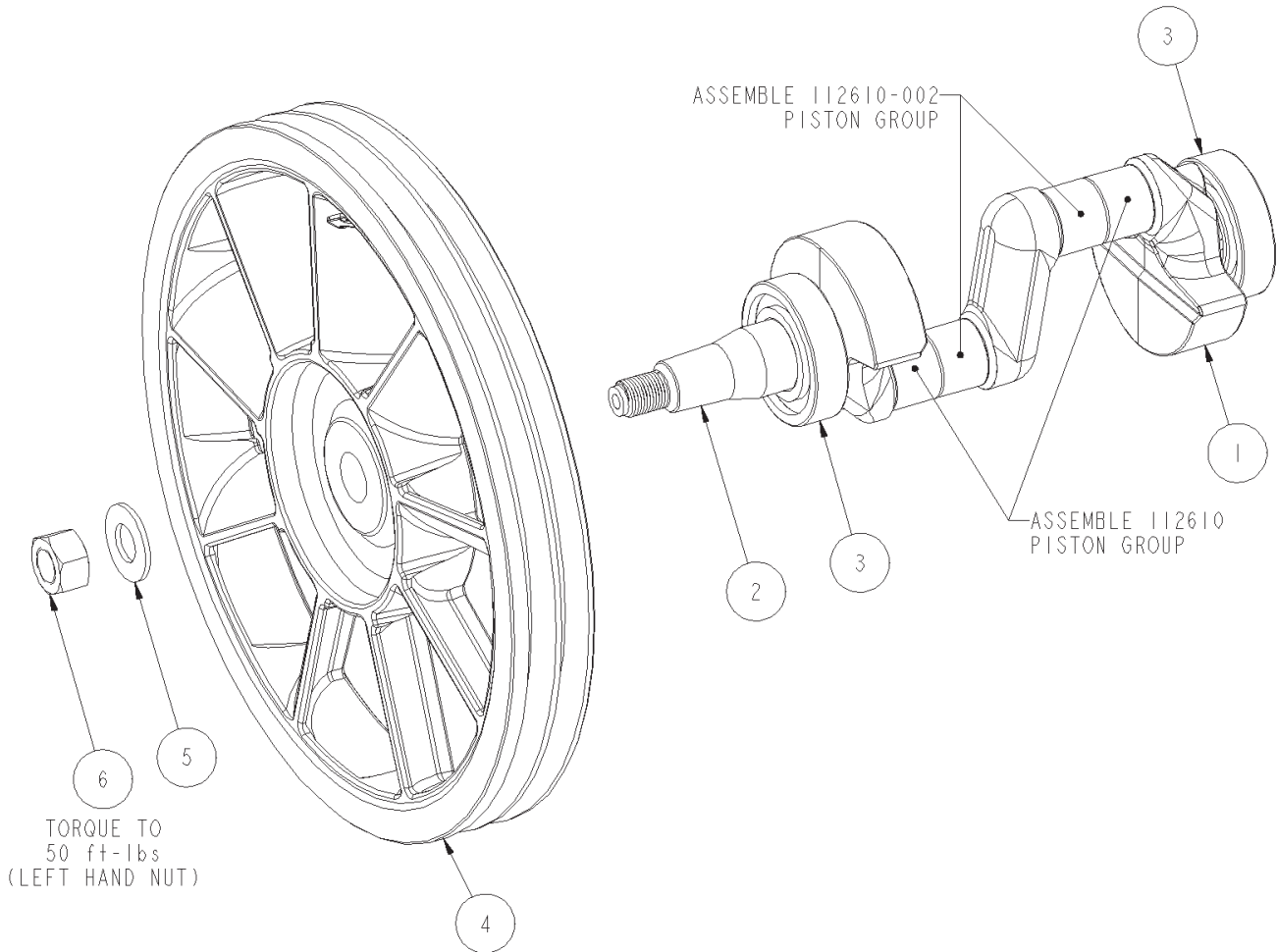

CRANKSHAFT GROUP 114941-004 BILL OF MATERIALS			
ITEM	PART NUMBER	QTY	DESCRIPTION
1	114873X005	1	CRANKSHAFT ASSEMBLY
2	114873-005	1	CRANKSHAFT
3	111107	2	BALL BEARING
4	114211-003	1	SHEAVE, 2 GROOVE, A SECTION
5	110428N062	1	FLAT WASHER
6	112607	1	HEX. NUT

CONNECTING ROD & PISTON GROUP 112610

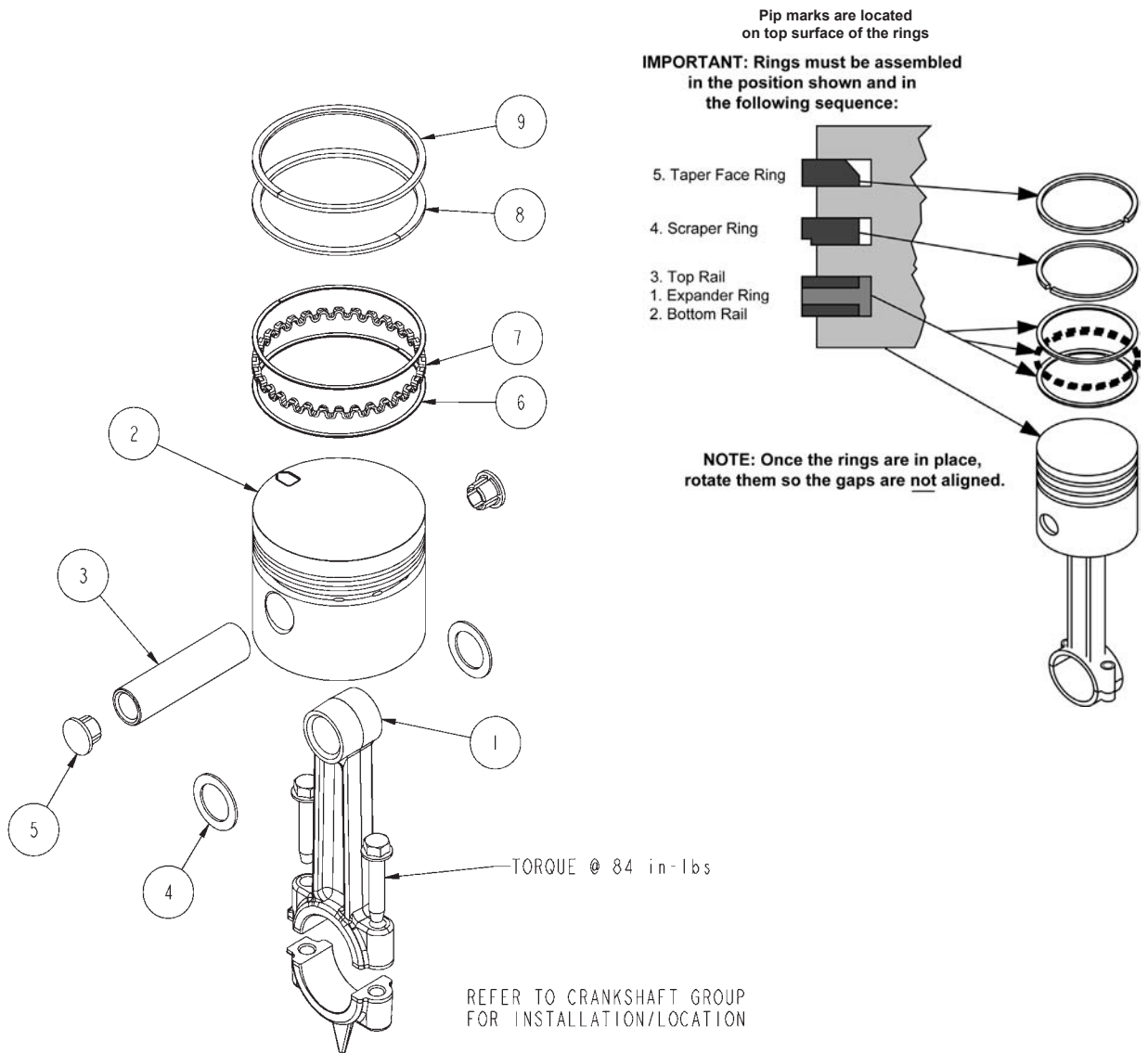

PISTON/CONROD AY 112610 BILL OF MATERIALS			
ITEM	PART NUMBER	QTY	DESCRIPTION
1	112583	1	AY, CON/ROD
2	112582	1	PISTON
3	110190-025	1	PISTON PIN
4	112597	2	NYLON WASHER
5	111105-002	2	PISTON PIN PLUG
6	112650	2	OIL RING RAIL
7	112651	1	OIL RING SPACER
8	112601	1	PISTON RING SCRAPER
9	112600	1	PISTON RING
MAINTENANCE PARTS (ORDER QTY PER PISTON)			
	113046	1	REPLACEMENT RING SET (INCLUDES ITEMS 6, 7, 8 & 9)
	112583K	1	REPLACEMENT CON/ROD (ITEM 1)

CONNECTING ROD & PISTON GROUP 112610-002

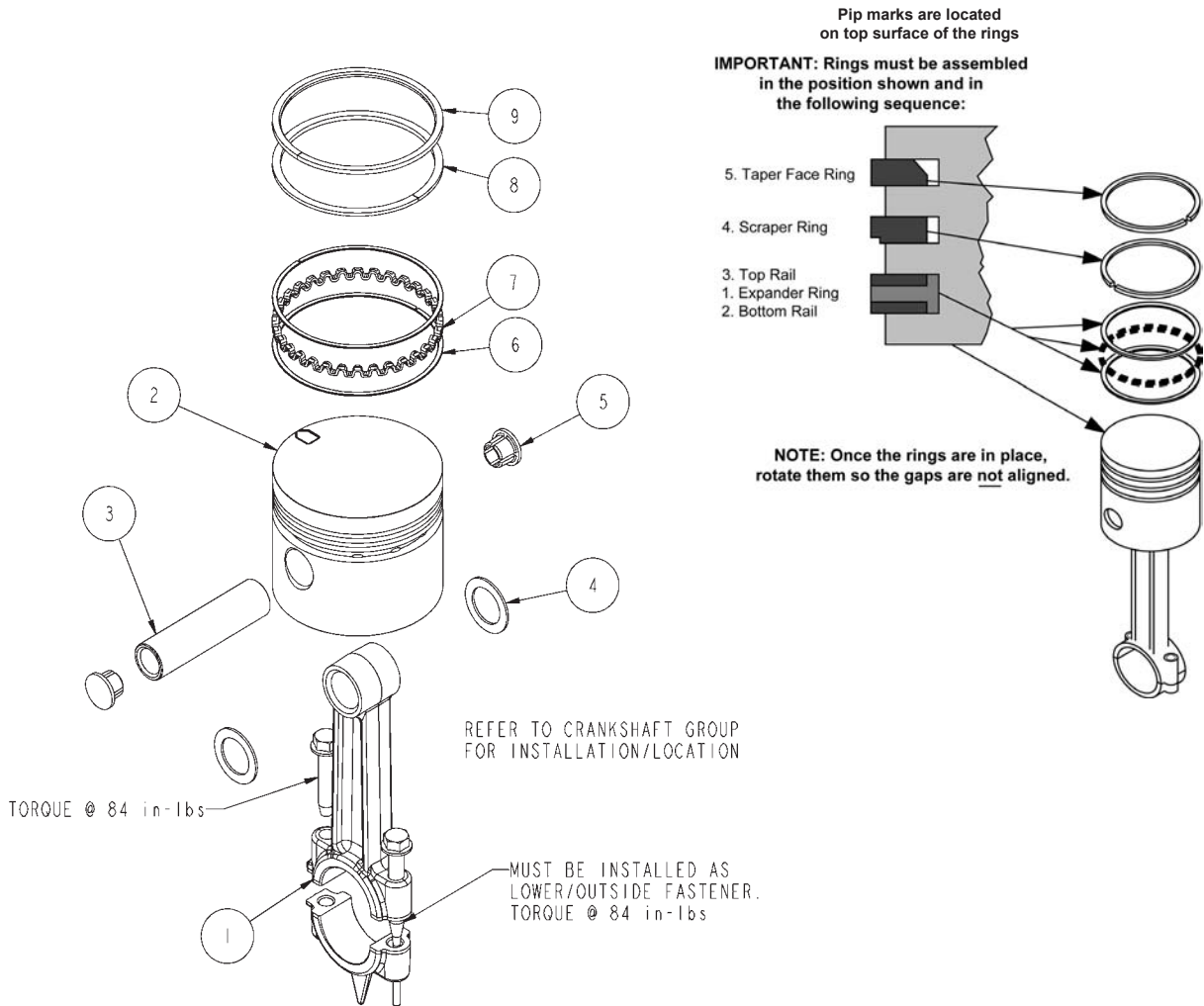

PISTON/CONROD AY 112610-002 BILL OF MATERIALS			
ITEM	PART NUMBER	QTY	DESCRIPTION
1	112583-001	1	AY, CON/ROD
2	112582	1	PISTON
3	110190-025	1	PISTON PIN
4	112597	2	NYLON WASHER
5	111105-002	2	PISTON PIN PLUG
6	112650	2	OIL RING RAIL
7	112651	1	OIL RING SPACER
8	112601	1	PISTON RING SCRAPER
9	112600	1	PISTON RING
MAINTENANCE PARTS (ORDER QTY PER PISTON)			
	113046	1	REPLACEMENT RING SET (INCLUDES ITEMS 6, 7, 8 & 9)
	112583K001	1	REPLACEMENT CON/ROD (TEM 1)

CYLINDER & HEAD GROUP 112640-009

(less head unloaders)

CYL/HEAD GROUP, QTS-5, PLAIN 112640-009 BILL OF MATERIALS	
ITEM	DESCRIPTION
1	GASKET
2	CYLINDER, AIR-COOLED (2.75 DIA)
3	GASKET, CYL/VALVE PLATE
4	VALVE PLATE ASSEMBLY
5	HEAD GASKET
6	HEAD
7	HEX, SCREW GRADE 8
8	WASHER
9	SCREW, CAP HEX, SEALANT, GRADE 5
10	PIPE ELBOW, 90° STREET, 1/2 NPT x 1/2 NPT
11	AIR FILTER
MAINTENANCE PARTS	
(ORDER QTY PER BANK)	
113047-001	VALVE REPAIR KIT (INCLUDES ITEM 3,4,5)
112845-06	AIR FILTER ELEMENT

LEFT BANK SHOWN - WHEN FACING COMPRESSOR FROM FLYWHEEL SIDE.
ITEM #10 IS NOT REQUIRED ON BASICS AND 5 HP 3450 RPM UNITS.

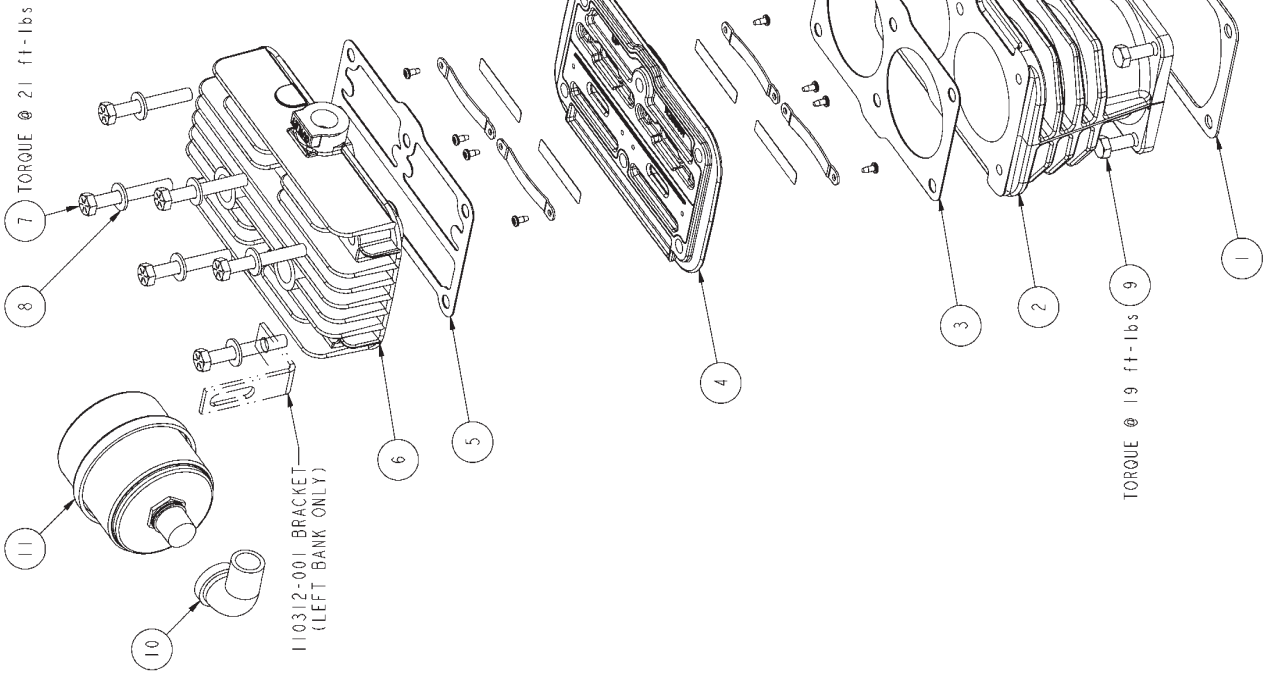

CYLINDER & HEAD GROUP 112640-010

(with head unloaders)

ITEM	PART NUMBER	QTY	DESCRIPTION
CYL/HEAD GROUP, QTS-5, 2 STAGE_UNLDR 112640-010 BILL OF MATERIALS			
1	112591	1	GASKET
2	112586	1	CYLINDER, AIRCOOLED (2.75 DIA)
3	112793	1	GASKET, CYL/VALVE PLATE
4	112588X	1	VALVE PLATE ASSEMBLY
5	114201-001	1	HEAD GASKET
6	115407-K18	6	HEX, SCREW GRADE 8
7	115384N031	6	WASHER
8	115037-K10	6	SCREW, CAP HEX, SEALANT, GRADE 5
9	114200X001	1	HEAD ASSEMBLY
10	114200-001	1	HEAD
11	111590X2	2	INTAKE UNLOADER
12	2708	1	TUBE FITTING, 90° ELBOW, 1/4T x 1/4P
13	124351-004	1	MALE BRANCH TEE 1/4T X 1/4P
14	110515-025	1	1/4" COPPER TUBING
15	21922	1	PIPE ELBOW, 90° STREET, 1/2 NPT x 1/2 NPT
16	112835-004	1	AIR FILTER
MAINTENANCE PARTS (ORDER QTY PER BANK)			
	113047-001	1	VALVE REPAIR KIT (INCLUDES ITEM 3,4,5)
	112845-06	1	AIR FILTER ELEMENT

LEFT BANK SHOWN - WHEN FACING COMPRESSOR FROM FLYWHEEL SIDE.
ITEM #10 IS NOT REQUIRED ON BASICS AND 5 HP 3450 RPM UNITS.

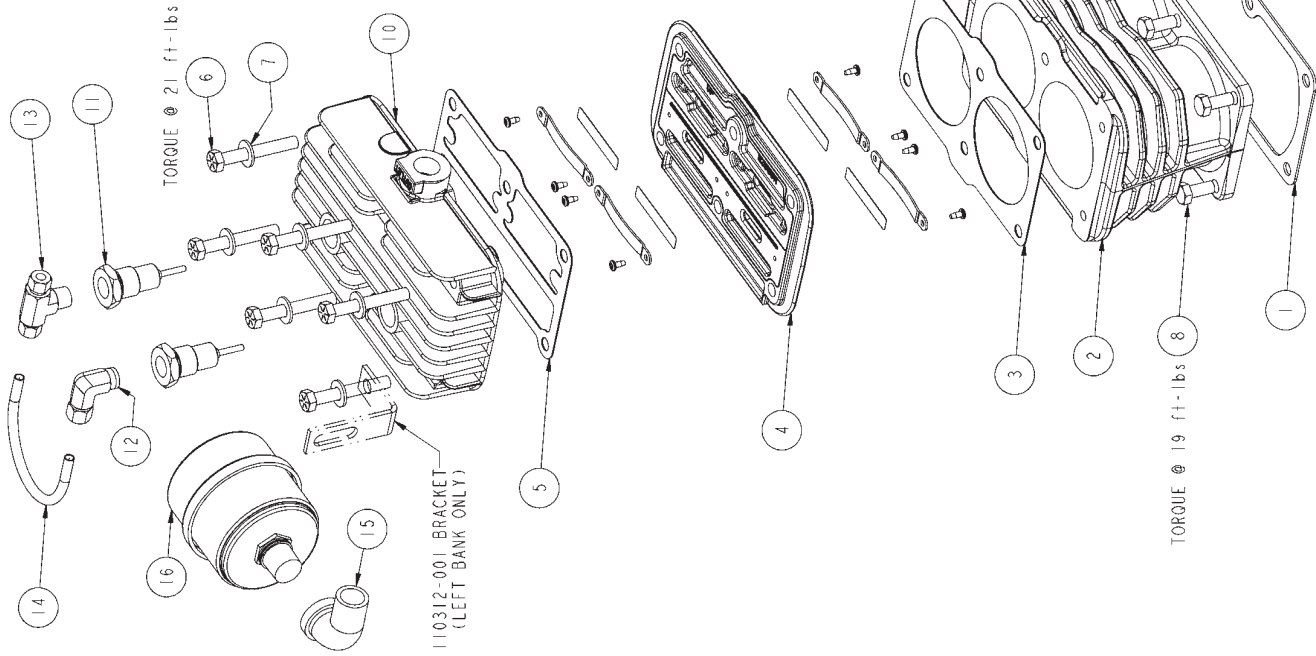

DISCHARGE MANIFOLD KIT 115469K001

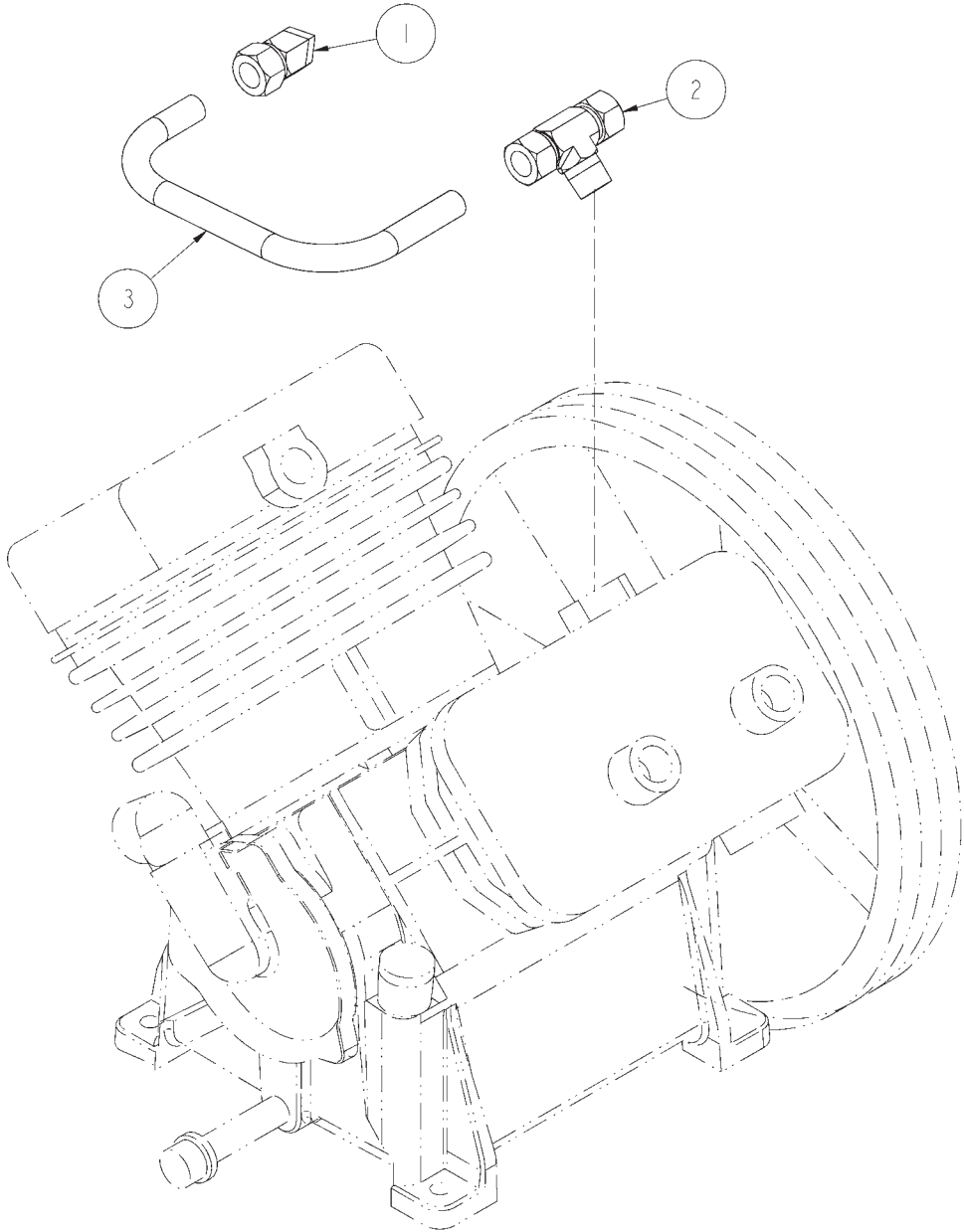

ITEM	PART NUMBER	QTY	DESCRIPTION
1	3145	1	TUBE FITTING, ELBOW
2	124351-008	1	TUBE FITTING, TEE
3	110515-050	1 FT	COPPER TUBE, .50 O.D.

TYPICAL UNIT REPAIR PARTS LIST

The parts listed here are for standard QTS-5 (up to 125 PSIG) units and may or may not be applicable to custom built units. Check with your local authorized Quincy distributor for parts that can be used for custom built units. Make sure the components you order are rated within the safe operating limits of your system. If you are doubtful about which components to order, contact your local Quincy distributor.

(QTS-5 simplex - 60 gal. vertical tank)

Qty	Part Number	Description		
1	114965P200	tank (200 PSIG max. working pressure)		
1	2713	tank drain valve		
1	111136-050	ball valve		
1	110514-200	pressure gauge		
1	110512-020	pressure switch with release valve (90-125 PSIG)		
1	111089-140	pressure relief valve (140 PSIG)		
1	110513-165	pressure relief valve (165 PSIG)		
3 ft.	110515-050	! discharge tube (1/2" copper tube to be formed by customer)		
2	110948-050	tube fitting (nut with sleeve)		
1	110921-275	check valve		
1	3145	tube fitting, elbow		
1	124351-008	tube fitting, tee		
1	111023-007	belt guard assembly		
	230v, 1Ø	230v, 1Ø	230/460v, 3Ø	
	3600 RPM	1800 RPM	1800 RPM	
1	127466I009	2023000868	124517-005	5 h.p. motor
1	5188-78	115033	115033	motor pulley
1		8924	8924	motor pulley bushing
1	110259A053	110258A056	110258A056	belt

! Pre-formed discharge tubes are available. Contact factory with model, serial number & tank size information.

QUINCY COMPRESSOR

STANDARD TERMS AND CONDITIONS

LEGAL EFFECT: Except as expressly otherwise agreed to in writing by an authorized representative of Seller, the following terms and conditions shall apply to and form a part of this order and any additional and/or different terms of Buyer's purchase order or other form of acceptance are rejected in advance and shall not become a part of this order.

The rights of Buyer hereunder shall be neither assignable nor transferable except with the written consent of Seller.

This order may not be canceled or altered except with the written consent of Seller and upon terms which will indemnify Seller against all loss occasioned thereby. All additional costs incurred by Seller due to changes in design or specifications, modification of this order or revision of product must be paid for by Buyer.

In addition to the rights and remedies conferred upon Seller by this order, Seller shall have all rights and remedies conferred at law and in equity and shall not be required to proceed with the performance of this order if Buyer is in default in the performance of such order or of any other contract or order with seller.

TERMS OF PAYMENT: Unless otherwise specified in the order acknowledgment, the terms of payment shall be 1% 15, net forty-five (45) days after shipment. These terms shall apply to partial as well as complete shipments. If any proceeding be initiated by or against Buyer under any bankruptcy or insolvency law, or in the judgment of Seller the financial condition of Buyer, at the time the equipment is ready for shipment, does not justify the terms of payment specified, Seller reserves the right to require full payment in cash prior to making shipment. If such payment is not received within fifteen (15) days after notification of readiness for shipment, Seller may cancel the order as to any unshipped item and require payment of its reasonable cancellation charges.

If Buyer delays shipment, payments based on date of shipment shall become due as of the date when ready for shipment. If Buyer delays completion of manufacture, Seller may elect to require payment according to percentage of completion. Equipment held for Buyer shall be at Buyer's risk and storage charges may be applied at the discretion of Seller.

Accounts past due shall bear interest at the highest rate lawful to contract for but if there is no limit set by law, such interest shall be eighteen percent (18%). Buyer shall pay all cost and expenses, including reasonable attorney's fees, incurred in collecting the same, and no claim, except claims within Seller's warranty of material or workmanship, as stated below, will be recognized unless delivered in writing to Seller within thirty (30) days after date of shipment.

TAXES: All prices exclude present and future sales, use, occupation, license, excise, and other taxes in respect of manufacture, sales or delivery, all of which shall be paid by Buyer unless included in the purchase price at the proper rate or a proper exemption certificate is furnished.

ACCEPTANCE: All offers to purchase, quotations and contracts of sales are subject to final acceptance by an authorized representative at Seller's plant.

DELIVERY: Except as otherwise specified in this quotation, delivery will be F. O. B. point of shipment. In the absence of exact shipping instruction, Seller will use its discretion regarding best means of insured shipment. No liability will be accepted by Seller for so doing. All transportation charges are at Buyer's expense. Time of delivery is an estimate only and is based upon the receipt of all information and necessary approvals. The shipping schedule shall not be construed to limit seller in making commitments for materials or in fabricating articles under this order in accordance with Seller's normal and reasonable production schedules.

Seller shall in no event be liable for delays caused by fires, acts of God, strikes, labor difficulties, acts of governmental or military authorities, delays in transportation or procuring materials, or causes of any kind beyond Seller's control. No provision for liquidated damages for any cause shall apply under this order. Buyer shall accept delivery within thirty (30) days after receipt of notification of readiness for shipment. Claims for shortages will be deemed to have been waived if not made in writing with ten (10) days after the receipt of the material in respect of which any such shortage is claimed. Seller is not responsible for loss or damage in transit after having received "In Good Order" receipt from the carrier. All claims for loss or damage in transit should be made to the carrier.

TITLE & LIEN RIGHTS: The equipment shall remain personal property, regardless of how affixed to any realty or structure. Until the price (including any notes given therefore) of the equipment has been fully paid in cash, Seller shall, in the event of Buyer's default, have the right to repossess such equipment.

PATENT INFRINGEMENT: If properly notified and given an opportunity to do so with friendly assistance, Seller will defend Buyer and the ultimate user of the equipment from any actual or alleged infringement of any published United States patent by the equipment or any part thereof furnished pursuant hereto (other than parts of special design, construction, or manufacture specified by and originating with Buyer), and will pay all damages and costs awarded by competent court in any suit thus defended or of which it may have had notice and opportunity to defend as aforesaid.

STANDARD WARRANTY: Seller warrants that products of its own manufacture will be free from defects in workmanship and materials under normal use and service for the period specified in the product instruction manual. Warranty for service parts will be Ninety (90) days from date of factory shipment. Electric Motors, gasoline and diesel engines, electrical apparatus and all other accessories, components and parts not manufactured by Seller are warranted only to the extent of the original manufacturer's warranty.

Notice of the alleged defect must be given to the Seller, in writing with all identifying details including serial number, type of equipment and date of purchase within thirty (30) days of the discovery of the same during the warranty period.

Seller's sole obligation on this warranty shall be, at its option, to repair or replace or refund the purchase price of any product or part thereof which proves to be defective. If requested by Seller, such product or part thereof must be promptly returned to seller, freight prepaid, for inspection.

Seller warrants repaired or replaced parts of its own manufacture against defects in materials and workmanship under normal use and service for ninety (90) days or for the remainder of the warranty on the product being repaired.

This warranty shall not apply and Seller shall not be responsible or liable for:

- (a) Consequential, collateral or special losses or damages;
- (b) Equipment conditions caused by fair wear and tear, abnormal conditions of use, accident, neglect or misuse of equipment, improper storage or damage resulting during shipping;
- (c) Deviation from operating instructions, specifications or other special terms of sale;
- (d) Labor charges, loss or damage resulting from improper operation, maintenance or repairs made by person(s) other than Seller or Seller's authorized service station.

In no event shall Seller be liable for any claims whether arising from breach of contract or warranty or claims of negligence or negligent manufacture in excess of the purchase price.

THIS WARRANTY IS THE SOLE WARRANTY OF SELLERS AND ANY OTHER WARRANTIES, WHETHER EXPRESS OR IMPLIED IN LAW OR IMPLIED IN FACT, INCLUDING ANY WARRANTIES OF MERCHANTABILITY AND FITNESS FOR PARTICULAR USE ARE HEREBY SPECIFICALLY EXCLUDED.

LIABILITY LIMITATIONS: Under no circumstances shall the Seller have any liability for liquidated damages or for collateral, consequential or special damages or for loss of profits, or for actual losses or for loss of production or progress of construction, whether resulting from delays in delivery or performance, breach of warranty, negligent manufacture or otherwise.

ENVIRONMENTAL AND OSHA REQUIREMENTS: At the time of shipment of the equipment from the factory, Quincy Compressor / Ortman Fluid Power will comply with the various Federal, State and local laws and regulations concerning occupational health and safety and pollution. However, in the installation and operation of the equipment and other matters over which the seller has no control, the Seller assumes no responsibility for compliance with those laws and regulations, whether by the way of indemnity, warranty or otherwise.

June 30, 2003



Reciprocating / Systems: 217.222.7700
E-mail: info@quincycompressor.com
Website: quincycompressor.com

